

## Renpenning Syndrome Maps to Xp11

Roger E. Stevenson,<sup>1</sup> J. Fernando Arena,<sup>2</sup> Elizabeth Ouzts,<sup>1</sup> Alice Gibson,<sup>3</sup> M. H. K. Shokeir,<sup>3</sup> Cindy Vnencak-Jones,<sup>4</sup> Herbert A. Lubs,<sup>2</sup> M. May,<sup>1</sup> and Charles E. Schwartz<sup>1</sup>

<sup>1</sup>Greenwood Genetic Center, Greenwood, SC; <sup>2</sup>University of Miami School of Medicine, Miami; <sup>3</sup>University Hospital, Saskatoon; and <sup>4</sup>Vanderbilt University, Nashville

### Summary

Mutations in genes on the X chromosome are believed to be responsible for the excess of males among individuals with mental retardation. Such genes are numerous, certainly >100, and cause both syndromal and non-syndromal types of mental retardation. Clinical and molecular studies have been conducted on the Mennonite family with X-linked mental retardation (XLMR) reported, in 1962, by Renpenning et al. The clinical phenotype includes severe mental retardation, microcephaly, up-slanting palpebral fissures, small testes, and stature shorter than that of nonaffected males. Major malformations, neuromuscular abnormalities, and behavioral disturbances were not seen. Longevity is not impaired. Carrier females do not show heterozygote manifestations. The syndrome maps to Xp11.2-p11.4, with a maximum LOD score of 3.21 (recombination fraction 0) for markers between DXS1039 and DXS1068. Renpenning syndrome (also known as “MRXS8”; gene RENS1, MIM 309500) shares phenotypic manifestations with several other XLMR syndromes, notably the Sutherland-Haan syndrome. In none of these entities has the responsible gene been isolated; hence, the possibility that two or more of them may be allelic cannot be excluded at present.

### Introduction

In 1962, Renpenning et al. (1962) reported mental retardation affecting 20 males in three generations of a Mennonite family in Canada. The founding couple had emigrated from the Ukraine to Plum Coulee, Manitoba, during the 1870s. From this location, subsequent gen-

erations dispersed throughout the farmlands of central and western Canada (Manitoba, Saskatchewan, Alberta, and British Columbia). The founding mother is presumed to have carried the mutation for this type of X-linked mental retardation (XLMR), since, in separate marriages, she had daughters who had affected sons.

Affected males were described as well built and physically strong, with head circumferences at the lower limits of normal and with somewhat prominent ears. They learned to walk at age 2–3 years and said simple words at age 3–4 years. With one exception, intelligence was severely impaired, with IQ measurements of 13–45. Two males had seizures, and two were blind (one in association with bilateral colobomas). Carrier females showed no abnormality.

Prior to Renpenning et al.’s study, few families with XLMR had been reported (Martin and Bell 1943; Allan et al. 1944; Losowsky 1961), and, during the 1960s and 1970s, the designation “Renpenning syndrome” (gene RENS1; MIM 309500 [http://www.ncbi.nlm.nih.gov/htbin-post/Omim]) came to be used as a generic designation for XLMR, although some preferred to see the term used only for nonsyndromic XLMR (Turner et al. 1971). Fox et al. (1980) restudied the family in 1980, reviewed the phenotype, and excluded fragile X syndrome as the diagnosis, on the basis of negative cytogenetic analysis for the Xq27.3 fragile site. The family has now been restudied by molecular techniques, and the gene has been mapped to Xp11.2-p11.4.

### Subjects and Methods

#### Case Reports

A partial pedigree is shown in figure 1. Renpenning et al. (1962) reported 20 affected males, although one male (V-18) was noted to be less severely involved. This male had an IQ measurement of 70, had 12 years of public schooling, and now works in a restaurant and lives alone. One affected male (V-26) lived in Mexico and was not evaluated. Eighteen males were severely affected, with IQ measurements of 13–45, and were unable to attend school. Although some were able to perform simple farm tasks, most eventually were placed in training schools or other institutions. Only one (III-11)

Received December 18, 1997; accepted for publication February 19, 1998; electronically published April 17, 1998.

Address for correspondence and reprints: Dr. Roger E. Stevenson, J. C. Self Research Institute of Human Genetics, Greenwood Genetic Center, 1 Gregor Mendel Circle, Greenwood, SC 29646. E-mail: karen@ggc.org

© 1998 by The American Society of Human Genetics. All rights reserved. 0002-9297/98/6205-0014\$02.00

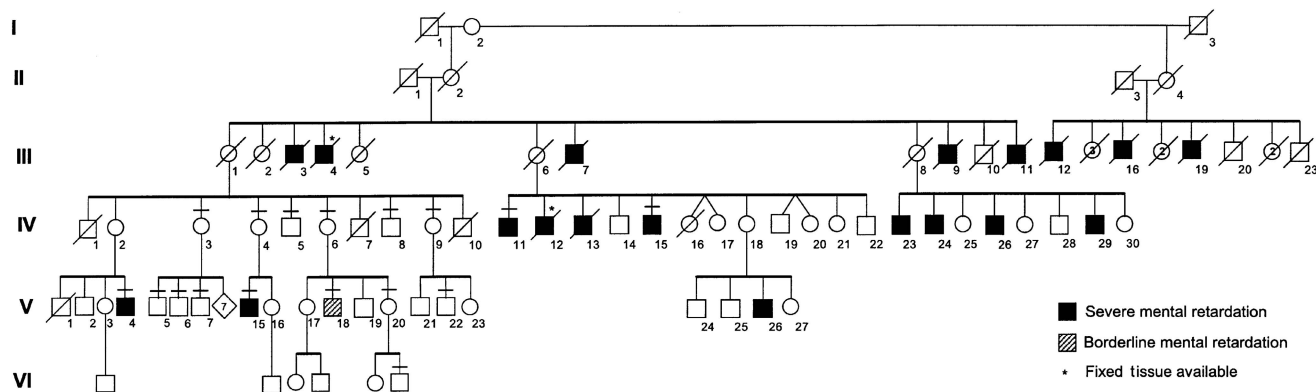

**Figure 1** Partial pedigree for kindred 8110. Bars over pedigree symbols denote individuals evaluated in the current study; asterisks above pedigree symbols denote individuals for whom fixed tissues were available.

died during childhood. Two were blind, one case (III-4) of unknown cause and one case (III-15) associated with bilateral colobomas and cataracts. Three males had seizures, and four had diabetes mellitus (table 1). An additional male with mental retardation, who was related through a normal male, was considered by Renpenning et al. (1962) to be a coincidental occurrence and is not shown on the pedigree. Obligate carriers were normal.

At the time of this study, four affected males (IV-11, IV-15, V-4, and V-15) and the male with mild mental impairment (V-18) were alive, and all were available for examination and blood samples. Brief summaries on these individuals are given below. Selected measurements are shown in table 1. Five women and seven unaffected males also participated. Only one obligate carrier (IV-4) was available. Tissue samples were available on two additional affected males (III-4 and IV-12).

IV-11 (J. F.) has been institutionalized for mental retardation since age 24 years. Details of the pregnancy and childhood are not known. His measurements at age 66 years are shown in table 1. He has microcephaly (occipitofrontal circumference 52.5 cm), and his height (157.8 cm) is shorter than that of unaffected relatives. The facies are characterized by central balding, up-slanting palpebral fissures (6.5° on the right, 3.5° on the left), and short philtrum (fig. 2).

IV-15 (I. F.) had global developmental delay from birth and has been institutionalized since age 2 years. He is blind secondary to ocular colobomas and cataracts. Measurements at age 59 years are shown in table 1.

V-4 (R. H.) had delay of developmental milestones, with walking at age 2 years and initial speech at age 3 years. He was placed in an institution at age 15 years, and at present he lives in a group home. Measurements at age 40 years are given in table 1. R. H. had no speech but understood simple conversations. The facies was characterized by central balding, microcephaly, up-slant-

ing palpebral fissures (6° on the right, 5° on the left), and short philtrum (fig. 2). With the exception of pectus excavatum, no malformations were noted. There were partial amputations of four digits on the left hand, because of an accident.

V-15 (E. F.) was born of a full-term and uncomplicated pregnancy, experienced global developmental delay, with walking at age 18 mo, never developed understandable speech, never attended school, and lives at home. He had several generalized seizures during childhood. Measurements at age 55 years are shown in table 1. The face had a squarish configuration, mildly up-slanting palpebral fissures, short philtrum, and everted lower lip (fig. 2). Deep-tendon reflexes were brisk, but clonus was not present.

V-18 (D. O.) reported that he had attended school for 12 years but had failed each year. He experienced the same learning difficulties in trade school. He now lives alone, drives a car, and works as an assistant in a restaurant. Measurements at age 44 years are given in table 1. His head was obviously small and measured below -2 SD. He had central balding, up-slanting palpebral fissures (7° on the right, 6.5° on the left), and nasal speech. Renpenning et al. (1962) and Fox et al. (1980) identified individual V-18 as having intellectual function much higher than that of other affected males in the family. They considered that he might be mentally impaired for some reason other than that which affected the other males, but they could not establish a cause for his mental retardation.

In addition to the foregoing information on V-18, reports from the family suggested that mild mental impairment might be present among other males in branches of the kindred that were not investigated in this study. A prevailing consideration within the family was that these younger, mildly affected males might have the same disorder as affected the older, severely affected

**Table 1****Selected Measurements in Kindred 8110**

SUBJECT'S CURRENT DESIGNATION (ORIGINAL DESIGNATION)	AGE(S) AT EXAMINATION(S) (years)	IQ <sup>a</sup>	PHYSICAL MEASUREMENT (PERCENTILE) <sup>a</sup>					COMMENT <sup>a</sup>
			Head Circumference (cm)	Height (cm)	Ear Length (cm)	Hand/Palm Length (cm/cm)	Testicular Volume (ml)	
Affected Males:								
III-3 (12)	70	15, 17	49.5 (<3)	–	...	...	...	Blind, diabetes
III-4 (13)	64	28	51.4 (<3)	...	...	...	...	
III-7 (16)	57	13	52.7 (<3)	...	...	...	...	Seizures, diabetes
III-9 (18)	53, 71	17, 27, 39	53.0 (<3)	162.0 (<3)	7.0 (90)	...	2.3/1.0	Diabetes
III-12 (21)	67, 84	35	54.0 (3)	160.0 (<3)	6.5 (55)	...	6.3/6.3	
III-16 (24)	60, 77	37	50.0 (<3)	154.0 (<3)	6.5 (55)	...	13.8/12.5	
III-19 (27)	54	24	48.3 (<3)	...	...	...	...	Diabetes
IV-11 (39)	37, 55, 66	20	52.4 (<3)	157.8 (<3)	6.9 (85)	17.5 (<3)/10.0	7.3/13.1	
IV-12 (40)	35, 53	30	53.2 (<3)	171.2 (25)	7.0 (90)	...	23.6/14.7	
IV-13 (41)	33, 51	45	50.7 (<3)	155.0 (<3)	7.0 (90)	...	6.3/4.8	
IV-15 (43)	30, 49, 59	18	52.2 (<3)	162.5 (<3)	6.7 (70)	17.2 (<3)/9.8	22.4/27.3	Colobomas, cataracts, seizures
V-4 (191)	11, 40	30	53.5 (<3)	169.4 (20)	6.4 (45)	18.1 (10)/10.6	...	Pectus excavatum
V-15 (203)	19, 39, 55	25	55.0 (15)	170.0 (20)	7.3 (97)	19.0 (35)/11.5	13.0/25.2	Seizures
Mild mental impairment:								
V-18 <sup>b</sup> (210)	14, 34, 44	70	52.0 (<3)	175.2 (50)	6.3 (35)	19.7 (65)/11.8	15.4/15.3	
Not affected:								
IV-5 (183)	74	...	57.0 (60)	177.8 (60)	7.6 (>97)	18.5 (20)/10.8	...	...
IV-8 (186)	70	...	59.1 (95)	177.8 (60)	...	19.6 (60)/11.2	...	...

<sup>a</sup> Ellipses (...) indicate that an observation was not available.

<sup>b</sup> Individual has borderline mental retardation and, with regard to the Xp11.2-p11.4 haplotype, is discordant with the more severely males.

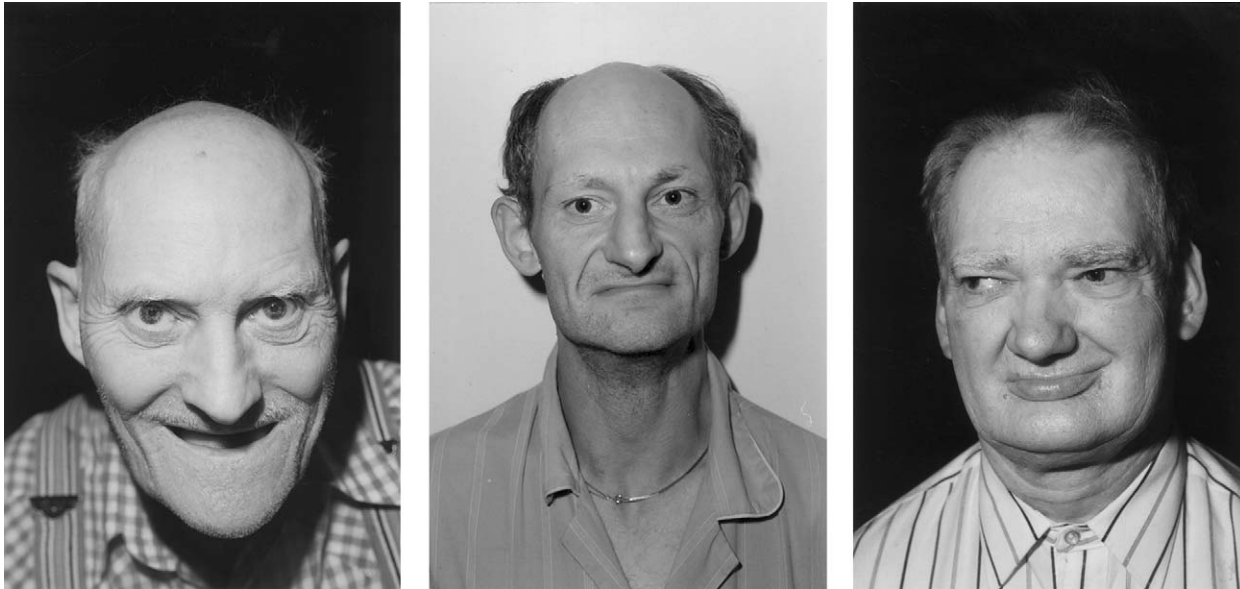

**Figure 2** Frontal facial views of, from left to right, IV-11 at age 66 years, showing microcephaly, central balding, and up-slanting palpebral fissures; V-4 at age 40 years, showing microcephaly, central balding, up-slanting palpebral fissures, and short philtrum; and V-15 at age 55 years, showing squarish facial configuration, short philtrum, and everted lower lip.

males—but with modified expression, because of the advantages of schooling and social opportunities. For this reason, V-18 has been designated by a hatch pattern in the pedigree shown in figure 1, and, for purposes of linkage analysis, his condition was considered “unknown.”

#### *Brain Anatomy*

Brain imaging has not been performed, but postmortem examinations of two affected males were available. Individual III-19 died at age 52 years. The brain weighed 780 g (below the 3d percentile) and showed no developmental, myelination, or degenerative changes. Individual IV-12 died at age 62 years. The brain weighed 984 g (below the 3d percentile) and showed arachnoid granulations on the external surface, a small cyst in the left frontal lobe, and arrangement of the neurons of the left temporal neocortex in vertical columns, which suggests a defect in neuronal migration or maturation.

#### *Other Laboratory Studies*

Renpenning et al. (1962) reported normal chromosome analysis (3 cases) and urine amino acid analysis (14 cases), and Fox et al. (1980) reported absence of the Xq27.3 fragile site in seven affected males. High-resolution chromosome analysis was normal in IV-6, IV-11, IV-15, and V-20. Molecular analysis of FMR1 was normal in IV-15.

#### *Molecular Studies*

Genomic DNA was isolated from peripheral blood, as described elsewhere (Schwartz et al. 1990). Purified DNA was diluted to a concentration of 105  $\mu\text{g/ml}$  and was stored at 4°C in TE (10 mM Tris-HCl pH 7.6, 1 mM EDTA). For archival material, genomic DNA was isolated from paraffin-embedded blocks according to the method described by Sukpanichnant et al. (1993), with some modifications. Five 10-mm sections were collected into a 1.5-ml microfuge tube and were deparaffinized in 2  $\times$  xylene for 30 min. Subsequently, the sections were washed in absolute 2  $\times$  ethanol for 10 min and were digested in 50 mM Tris pH 8.5, 1 mM EDTA, 0.5% Tween 20, and proteinase K (200  $\mu\text{g/ml}$ ) for  $\geq 3$  h at 50°C. Proteins were removed by extraction using phenol, phenol/chloroform, and chloroform. The aqueous layer was removed, ethanol precipitated, and resuspended in 1  $\times$  TE. Varying amounts of template DNA were used for each PCR-microsatellite reaction. Only microsatellite markers with allele sizes <230 bp were used for amplification of this material.

For Southern blot analysis, 5  $\mu\text{g}$  of DNA was digested with various restriction endonucleases, according to the supplier's recommendations, and the resulting fragments were separated on a 0.7% agarose gel and were transferred to a nylon membrane (MSI). Subsequent prehybridization and hybridizations were performed according to the procedure of Schwartz et al. (1990).

For microsatellite analysis, specific dinucleotide or tri-

Table 2

Two-Point LOD Scores between X Chromosome Loci and RENS1

LOCUS (LOCATION)	LOD SCORE AT RECOMBINATION FRACTION OF						MAXIMUM RE-COMBINATION FRCATION	MAXIMUM LOD SCORE
	.001	.01	.05	.1	.2	.3		
DXS443 (Xp22.13)	-1.48	-.53	.06	.21	.21	.10	.15	.23
3'DMD (Xp21.2)	-9.97	-7.29	-4.15	-2.75	-1.41	-.71	.50	.25
DXS1068 (Xp11.4)	-5.98	-3.01	-1.04	-.30	.23	.35	.30	.35
DXS8015 (Xp11.4)	3.20	3.15	2.90	2.59	1.93	1.22	.00	3.21
DXS8012 (Xp11.4)	3.04	2.99	2.77	2.49	1.87	1.19	.00	3.04
MAOA (Xp11.3)	1.04	1.02	.93	.81	.59	.38	.00	1.04
DXS8035 (Xp11.3)	3.20	3.15	2.91	2.61	1.96	1.26	.00	3.21
DXS1003 (Xp11.2)	3.13	3.09	2.88	2.61	2.01	1.32	.00	3.13
DXS255 (Xp11.2)	1.60	1.57	1.45	1.29	.94	.54	.00	1.66
DXS1039 (Xp11.2)	-1.12	-.14	.44	.61	.63	.50	.15	.65
DXS988 (Xp11.2)	.25	.25	.21	.17	.09	.03	.00	.26
DXS991 (Xp11.2)	.99	.98	.90	.81	.61	.41	.00	1.00
HumARA (Xq12)	-1.09	-.13	.42	.53	.45	.25	.12	.50
DXS1111 (Xq12)	1.75	1.72	1.58	1.39	.98	.54	.00	1.76
DXS983 (Xq13)	.13	1.10	1.66	1.76	1.57	1.16	.10	1.76
DXS566 (Xq13)	-13.36	-8.34	-4.78	-3.22	-1.69	-.84	.50	.16
DXS986 (Xq13)	-2.60	-2.56	-2.36	-2.10	-1.55	-.97	.50	.17
DXS326 (Xq21.2)	.77	.75	.66	.55	.33	.12	.00	.77
DXS458 (Xq21)	-1.42	-.45	.18	.31	.33	.21	.15	.35
DXS456 (Xq22)	-4.93	-3.04	-1.62	-.99	-.42	-.15	.48	.00
DXS424 (Xq24)	-7.61	-5.10	-2.58	-1.56	-.68	-.29	.53	.01
DXS425 (Xq26)	-9.26	-6.99	-3.04	-2.53	-1.21	-.54	.56	.03
HPRT (Xq26)	-2.01	-1.02	-.34	-.09	.07	.10	.28	.10
DXS548 (Xq28)	-5.08	-3.19	-1.77	-1.15	-.55	-.25	.55	.01

nucleotide polymorphisms were generated, as reported by Nelson et al. (1995) or Dib et al. (1996). In most instances, the forward primers were synthesized and labeled with fluorescein amidite (FluorePrime; Pharmacia), by a Beckman 1000 DNA synthesizer, and were desalted through a Sephadex G-25 (NAP-10 columns; Pharmacia). In some amplifications, the forward primer was labeled with X-ATP, by use T4 kinase. The polymorphisms generated from lymphocyte DNA were detected by an Automated Laser Fluorescent sequencer (ALF) (Pharmacia) and the software package Automated Linkage Preprocessor (ALP) (Mansfield et al. 1994). Radiolabeled amplicons generated from archived DNA were subjected to electrophoresis on a 6% denaturing polyacrylamide gel. Autoradiography was at  $-70^{\circ}\text{C}$  for 3-18 h.

Two-point linkage analysis was conducted by means of the program MLINK of the LINKAGE package (Lathrop and Lalouel 1984), and multipoint analysis was by LINKMAP (Lathrop et al. 1985). For the latter, genetic distances were calculated by means of Haldane's mapping function, based on previously published recombination frequencies (Nelson et al. 1995). The mutation rate and gene frequency were set at  $3 \times 10^{-6}$  and .0001, respectively. Penetrance was set at 100% for males and at 0% for females. The status of individual

V-18 was coded as unknown because of his borderline IQ and normal height.

## Results

Two point disease-to-marker linkage analysis using markers spanning the X chromosome indicated possible linkage to Xp11.2 and Xq12 (with LOD scores of 1.66 and 1.76 at zero recombination), for DXS255 and DXS1111, respectively (table 2). Further analysis, using additional markers in Xp11.2-p11.4, found markers DXS1003, DXS8015, and DXS8012 to be tightly linked to the disease ( $\theta = .00$ ) with LOD scores of 3.13, 3.21, and 3.04, respectively, whereas markers in Xq12 (AR and DXS983) exhibited recombination (table 2 and fig. 3). The combination of these data indicates that the RENS1 gene is likely located on the proximal short arm of the X chromosome, in the region flanked by DXS1039 (proximal) and DXS1068 (distal).

Multipoint analysis was used to determine, if possible, the most likely location for RENS1, within the region flanked by DXS1039 and DXS1068. The results, as shown in figure 4, gave a maximum LOD score of 3.45 for a broad region flanked by MAOA and DXS1003. The region between DXS1039 and DXS1068 covers ~8 cm, whereas the region between MAOA and DXS1003 covers ~3 cm (Nelson et al. 1995).

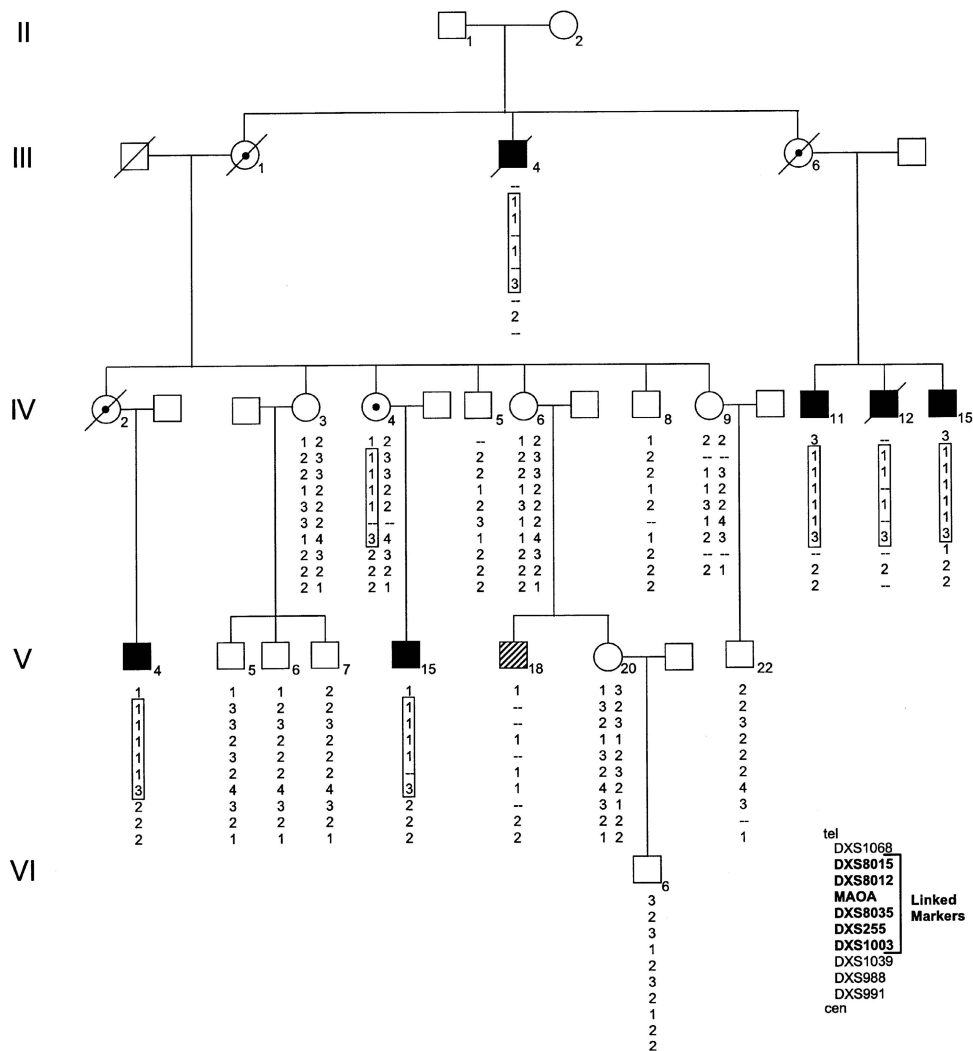

**Figure 3** Haplotype for markers in Xp11-p21. The boxed haplotype segregates with mental retardation. Studies of III-3 and IV-12 used fixed tissues.

The haplotype for individual V-18, for microsatellite markers in Xp11.2-11.4, was discordant vis-à-vis that of the other more severely impaired males (fig. 3). He is thus considered not affected, on the basis of this linkage analysis.

**Discussion**

During the 1970s, the term “Renpenning syndrome” came to be used as a generic term for XLMR (Richards 1970; Gerrard and Renpenning 1974; Steele and Chorazy 1974; Howard-Peebles et al. 1979; Jennings et al. 1980; McLaughlin and Kriegsmann 1980; Proops and Webb 1981; Archidiacono et al. 1987). This broad usage was applied to syndromic XLMR, including fragile X syndrome, and to nonsyndromic XLMR. Turner et al.

(1970, 1971, 1972) argued that this term should be used only for nonsyndromic XLMR—specifically, for cases lacking macrocephaly or microcephaly, epilepsy, major malformations or more than one minor malformation, and neurological signs. We propose that these practices be abandoned and that the term “Renpenning syndrome” be reserved for that condition that maps to Xp11.2-11.4 and is characterized by severe mental impairment, microcephaly, short stature, and small testes. Those males with XLMR who lack physical, behavioral, or neurological findings should be designated as having “nonsyndromic (or “nonspecific”) XLMR,” at least in the short term, until the responsible genes are isolated.

Robledo et al. (1994) reported evidence for linkage of RENS1 to markers in both Xp11.23-p11.3 and Xq21.33-Xq26, in a family previously reported by Ar-

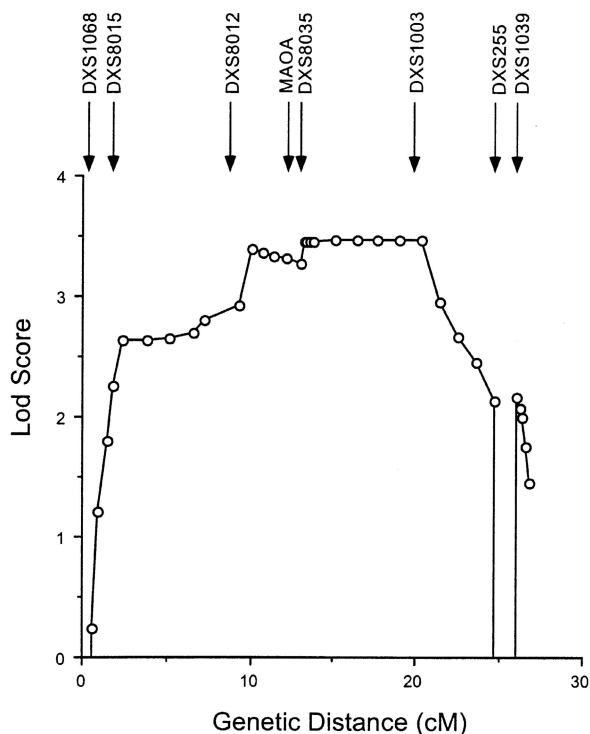

**Figure 4** LOD score of linkage of the RENS1 locus, multipoint analysis vs. markers in Xp11.2-p21. The genetic distances, calculated as described in the Subjects and Methods section, were based on the following recombination frequencies: DXS1068-.025-DXS8015-.07-DXS8012-.35-MAOA-.01-DXS8035-.065-DXS1003-.055-DXS255-.01-DXS1039. The multipoint LOD-score values correspond to location scores divided by 4.6.

chidiacono et al. (1987). Although a LOD score of 2.71 was found for both locations, the authors considered one of the two locations to be erroneous and probably explainable by double recombinations between the disease and one group of markers.

Localization of RENS1 to Xp11.2-11.4 places the responsible gene in a region overlapping the localizations of a number of XLMR syndromes (fig. 5); these include Prieto (MRXS2), Sutherland-Haas (MRXS3), Porteous, West, Hamel, Wilson-Turner (MRXS6), and Miles-Carpenter (MRXS4) syndromes (Sutherland et al. 1988; Miles and Carpenter 1991; Wilson et al. 1991; Porteous et al. 1992; Lubs et al. 1996; Prieto et al. 1997; Claes et al., in press; Hamel et al., in press-a, in press-b). The genes for monoamine oxidase A deficiency and Norrie disease are also located in this interval. Renpenning syndrome may be distinguished from these conditions on the basis of physical features, severity of mental impairment, and laboratory testing. Such exclusion must be considered tenuous, at least with regard to Sutherland-Haas syndrome, with which Renpenning syndrome shares several manifestations: short stature, microcephaly, and small testes occur in both syndromes. Males

with Sutherland-Haas syndrome may have pectus excavatum, scoliosis, stiffness of small joints, and pes cavus, skeletal findings that were not noted in the index family with Renpenning syndrome. This degree of phenotypic discordance should not exclude the possibility that the two conditions arise from mutations of the same gene.

Likewise, the localization of RENS1 overlaps with that of a number of families with nonsyndromic XLMR. Molecular technology has brought the capacity to distinguish the nonsyndromic XLMR families on the basis of linkage analysis. Since 1988, 60 families with nonsyndromic XLMR have been assigned "MRX" (i.e., mental retardation caused by X-linked genes) numbers on the basis of linkage analysis, with LOD scores >2.0 (Lubs et al., in press). These families constitute ≥10 exclusive linkage groups (Gedeon et al. 1996; Lubs et al. 1996). Since this partition of the X chromosome leaves room for additional intervening "MRX" conditions and does not preclude the presence of several "MRX" genes in each linkage group, the total number of "MRX" conditions cannot be given.

It is quite possible that Renpenning syndrome may be allelic with one or more of the 23 "MRX" conditions that overlap the Xp11.2-p11.4 interval (fig. 5). This possibility can be examined only with identification and mutational analysis of the RENS1 gene. Until recently, no gene responsible for nonsyndromal XLMR had been isolated and characterized. Two genes, the FMR2 gene, which causes fragile XE syndrome, and the GDI gene, which causes MRX41 and MRX48, have now been

**Table 3**

**Summary of Reports (Prior to 1970) of X-Linked Conditions in Which Mental Retardation Was the Predominant Manifestation**

Original Report	Follow-up Study	Syndrome	Gene Localization
Martin and Bell (1943)	Richards et al. (1981)	Fragile X	Xq27.3 (FMR1)
Allan et al. (1944)	Schwartz et al. (1990), Stevenson et al. (1990)	Allan-Herndon-Dudley	Xq13-q21
Losowsky (1961)	R. F. Mueller, personal communication	Fragile X	Xq27.3 (FMR1)
Renpenning et al. (1962)	Fox et al. (1980), present report	Renpenning	Xp11.2-p11.4
Dunn et al. (1962-63)	Fox et al. (1980)	Fragile X	Xq27.3 (FMR1)
Snyder and Robinson (1969)	Arena et al. (1996)	Snyder-Robinson	Xp21.3-p22.1
Lubs (1969)	...	Fragile X	Xq27.3 (FMR1)

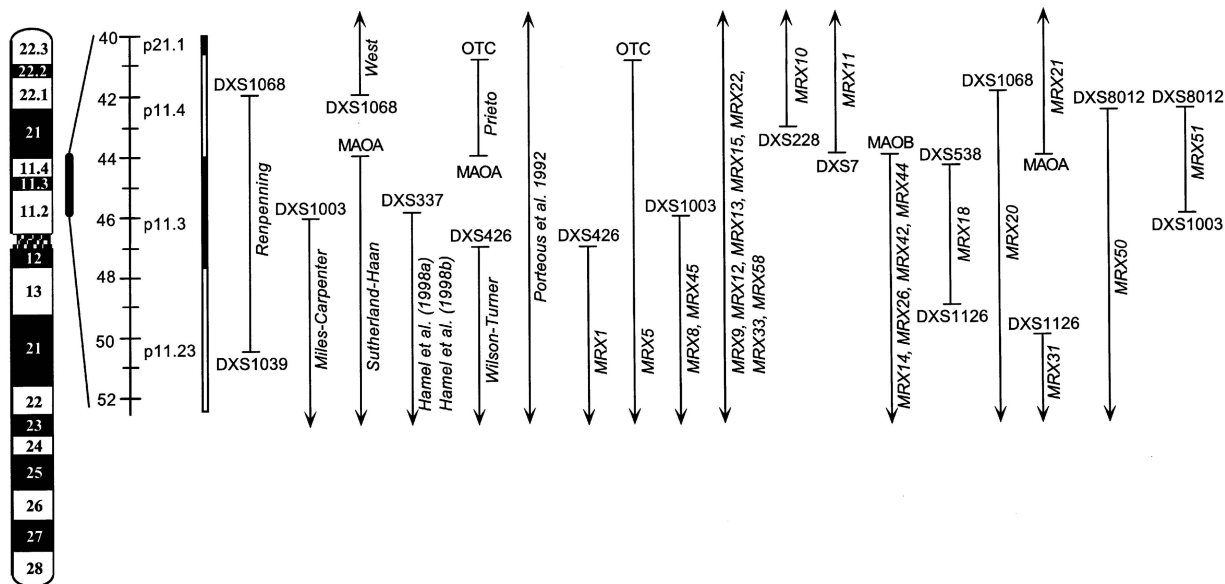

**Figure 5** Idiogram of Xp11.2-p21.1, showing linkage limits for RENS1 and for Sutherland-Haan, Wilson-Turner, West, Hamel, and Prieto syndromes and for 23 families with nonsyndromal XLMR (Claes et al., in press; Hamel et al. in press-a, in press-b; Lubs et al., in press). The megabase marker is according to the study by Nelson et al. (1995).

identified and mapped to Xq28 (Gecz et al. 1996; Gu et al. 1996; Hamel et al. 1996; des Portes et al. 1997).

Microdeletions in Xp have been described in two families with nonsyndromic XLMR. Billuart et al. (1996) found a deletion in Xp21.3-22.1 in a 9-year-old boy with isolated mental retardation, and Raeymaekers et al. (1996) described a deletion of unknown size in Xp22 in a family with six males with moderate mental retardation. Both of these short-arm deletions are located distal to the RENS1 linkage limits. An X;autosome translocation with a breakpoint in Xp11 has also been associated with nonsyndromic XLMR, but the gene interrupted by the translocation has not been isolated (van der Maarel et al. 1996)

A number of candidate genes located in the linkage interval must be systematically tested. They include those for synapsin I (SYNI), GATA-binding protein 1 (GATA1), synaptophysin (SYP), zinc-finger protein 21 (ZNF21, KOX14), zinc-finger protein 81 (HFZ20), transcription factor E3 (TFE3), cell-surface glycoprotein A15, ubiquitin-activating enzyme E1, and zinc-finger protein 37 (ZNF31).

With the regional mapping of RENS1, all families with XLMR that have been reported prior to the initial report (by Lubs in 1969) of the fragile X syndrome have now been restudied (table 3). The family reported by Martin and Bell (1943) was restudied by Richards et al. (1981) and was shown to have fragile X syndrome. Likewise, the families reported by Losowsky (1961) and Dunn et al. (1962-63) have fragile X syndrome (Fox et al. 1980; R. F. Mueller, personal communication). The Miami-

Greenwood XLMR study group has clinically defined and mapped the entities reported by Allan et al. (1944), Snyder and Robinson (1969), and the present report. The genes responsible for the latter three conditions have yet to be isolated. It is of interest that four of the seven families listed in table 3 have fragile X syndrome.

It seems appropriate to conclude with a historical note regarding the circumstances that, in 1962, led to the description of this entity. Hans Renpenning was a medical student at the University of Saskatchewan Medical School (Saskatoon) during the years 1956-60. After his sophomore year, he worked with Dunn and Gerrard, on the clinical delineation of a German family in which 20 males with mental retardation had occurred in two generations. In the course of discussing this project with his family in the Swift Current area, his father suggested that he might also study a local Mennonite family in which a number of males had mental retardation. The suggestion was followed, and investigation of the family proceeded rapidly, culminating in the 1962 publication in the *Canadian Medical Association Journal*. An article on the first family being studied with Dunn and Gerrard was published 6 mo later (Dunn et al. 1962-63). Within that report is contained the first published photograph of a patient with the phenotype now recognized as fragile X syndrome. In light of current understanding of this syndrome, it is of interest that, in addition to noting craniofacial features (elongated face with large ears and prominent lower jaw), the authors found mild expression in females and suspected transmission of the gene through a normal male.



Hans Renpenning thus joins the short list of physicians and scientists (including Lesch, Klinefelter, and Best) who made a benchmark contribution to medicine during their student years. For 30 years, he practiced ophthalmology in Saskatoon, retiring in 1995. He now divides his time between Arizona and Saskatchewan.

## Acknowledgment

This work was supported in part by National Institutes of Health grant HD26202 to H.A.L. and C.E.S. and by the South Carolina Department of Disabilities and Special Needs. Karen Buchanan produced the manuscript and figures. We thank the family members of kindred 8110 for their participation and assistance.

## References

- Allan W, Herndon CN, Dudley FC (1944) Some examples of the inheritance of mental deficiency: apparently sex-linked idiocy and microcephaly. *Am J Ment Defic* 48:325-334
- Archidiacono N, Rocchi M, Rinalki A, Filippi G (1987) X-linked mental retardation. II. Renpenning syndrome and other types (report of 14 families). *J Genet Hum* 35:381-398
- Arena JF, Schwartz CE, Ouzts L, Stevenson RE, Miller M, Garza J, Nance M, et al (1996) X-linked mental retardation with thin habitus, asymmetric face and prominent lower lip: linkage to Xp21.3-p22.12. *Am J Med Genet* 64:50-58
- Billuart P, Vinet MC, Portes V, Llense S, Richard L, Moutard ML, Recan D, et al (1996) Identification by STS PCR screening of a microdeletion in Xp21.3-22.1 associated with non-specific mental retardation. *Hum Mol Genet* 5:977-979
- Claes S, Devriendt K, Laga L, Raeymaekers P, Cassiman JJ, Fryns JP. Mapping of a genetic factor for the X-linked infantile spasms syndrome (MIM 308350) to Xp11.4-Xpter in two pedigrees. *Am J Med Genet* (in press)
- des Portes V, Billuart P, Carrie A, Bachner L, Bienvenu T, Vinet MC, Beldjord C, et al (1997) A gene for dominant nonspecific X-linked mental retardation is located in Xq28. *Am J Hum Genet* 60:903-909
- Dib C, Faure S, Fizames C, Samson D, Drouot N, Vignal A, Millasseau P, et al (1996) A comprehensive genetic map of the human genome based on 5,264 microsatellites. *Nature* 380:152-154
- Dunn HG, Renpenning H, Gerrard JW, Tabata T, Federoff S (1962-63) Mental retardation as a sex-linked defect. *Am J Ment Defic* 67:827-848
- Fox P, Fox D, Gerrard JW (1980) X-linked mental retardation: Renpenning revisited. *Am J Med Genet* 7:491-495
- Geçç J, Gedeon AK, Sutherland GR, Mulley JC (1996) Identification of the gene FMR2, associated with FRAXE mental retardation. *Nat Genet* 13:105-108
- Gedeon AK, Donnelly AJ, Mulley JC, Kerr B, Turner G (1996) How many X-linked genes for non-specific mental retardation (MRX) are there? *Am J Med Genet* 64:158-162
- Gerrard JW, Renpenning HJ (1974) Sex-linked mental retardation. *Lancet* 1:1346
- Gu Y, Shen Y, Gibbs RA, Nelson DL (1996) Identification of FMR2, a novel gene associated with the FRAXE CCG repeat and CpG island. *Nat Genet* 13:109-113
- Hamel BCJ, Kremer H, Wesby-van Swaay E, van den Helm B, Smits APT, Oostra BA, Ropers H-H, et al (1996) A gene for nonspecific X-linked mental retardation (MRX41) is located in the distal segment of Xq28. *Am J Med Genet* 64:131-133
- Hamel BCJ, Breslau-Siderius LJ, van Bokhoven H, van den Helm B, Kremer H, Heineman-de Boer JA, Ropers HH, et al. A new X-linked mental retardation syndrome with cleft lip/palate maps to Xp11.3-q21.3. *Am J Med Genet* (in press-a)
- Hamel BCJ, Renier WO, Wesseling P, van den Helm BA, Kremer H, Ropers HH, Mariman ECM. A new X-linked neurodegenerative syndrome with mental retardation, blindness, convulsions, spasticity, dysmyelination, and early death maps to the pericentromeric region. *Am J Med Genet* (in press-b)
- Howard-Peebles PN, Stoddard GR, Mims MG (1979) Familial X-linked mental retardation, verbal disability, and marker X chromosomes. *Am J Hum Genet* 31:214-222
- Jennings M, Hall JG, Hoehn H (1980) Significance of phenotypic and chromosomal abnormalities in X-linked mental retardation (Martin-Bell or Renpenning syndrome). *Am J Med Genet* 7:417-432
- Lathrop GM, Lalouel JM (1984) Easy calculations of lod scores and genetic risks on small computers. *Am J Hum Genet* 36:460-465
- Lathrop GM, Lalouel JM, Julier C, Ott J (1985) Multilocus linkage analysis in humans: detections of linkage and estimation of recombination. *Am J Hum Genet* 37:482-498
- Losowsky MS (1961) Hereditary mental defect showing the pattern of sex influence. *J Ment Defic Res* 5:60-62
- Lubs HA (1969) A marker X chromosome. *Am J Hum Genet* 21:231-244
- Lubs HA, Chiurazzi P, Arena JF, Schwartz C, Tranebjaerg L, Neri G (1996) XLMR genes: update 1996. *Am J Med Genet* 64:147-157
- . XLMR genes: update 1998. *Am J Med Genet* (in press)
- Mansfield DC, Brown AF, Green DK, Carothers AD, Morris SW, Evans HJ, Wright AF (1994) Automation of genetic linkage analysis using fluorescent microsatellite markers. *Genomics* 24:225-233
- Martin JP, Bell J (1943) A pedigree of mental defect showing sex-linkage. *J Neurol Psychiatry* 6:154-157
- McLaughlin JF, Kriegsmann E (1980) Developmental dyspraxia in a family with X-linked mental retardation (Renpenning syndrome). *Dev Med Child Neurol* 22:84-92
- Miles JH, Carpenter NJ (1991) Unique X-linked mental retardation syndrome with fingertip arches and contractures linked to Xq21.31. *Am J Med Genet* 38:215-223
- Nelson DL, Ballabio A, Cremers F, Monaco AP, Schlessinger D (1995) Report of the Sixth International Workshop on X Chromosome Mapping 1995. *Cytogenet Cell Genet* 71:307-342
- Porteous MEM, Johnson H, Burm J, Curtis A, Lindsay S, Bhattacharya SS, Goodship JA (1992) A new mental retardation syndrome mapping to the pericentromeric region of the X-chromosome. *Am J Hum Genet Suppl* 51:A106
- Prieto F, Badia L, Mulas F, Monfort A, Mora F (1987) X-

- linked dysmorphic syndrome with mental retardation. *Clin Genet* 32: 326–334
- Proops R, Webb T (1981) The fragile X chromosome in the Martin-Bell-Renpenning syndrome and in males with other forms of familial mental retardation. *J Med Genet* 18: 366–373
- Raeymaekers P, Lin J, Gu XX, Sockarman D, Cassiman J-J, Fryns J-P, Marynen P (1996) Non-specific mental retardation is probably caused by a microdeletion in Belgian family. *Am J Med Genet* 64:16
- Renpenning H, Gerrard JW, Zaleski WA, Tabata T (1962) Familial sex-linked mental retardation. *Can Med Assoc J* 87:954–956
- Richards BW (1970) Renpenning syndrome. *Lancet* 2:520
- Richards BW, Sylvester PE, Brooker C (1981) Fragile X-linked mental retardation: the Martin-Bell syndrome. *J Ment Defic Res* 25:253–256
- Robledo R, Melis P, Siniscalco M, Marchi J, Laficara F, Rinaldi A, Rocchi M, et al (1994) +2.71 LOD score at zero recombination is not sufficient for establishing linkage between X-linked mental retardation and X-chromosome markers. *Am J Med Genet* 64:134–136
- Schwartz CE, Ulmer J, Brown A, Pancoast I, Goodman HO, Stevenson RE (1990) Allan Herndon syndrome. II. Linkage to DNA markers in Xq21. *Am J Hum Genet* 47:454–458
- Snyder RD, Robinson A (1969) Recessive sex-linked mental retardation in the absence of other recognizable abnormalities. Report of a family. *Clin Pediatr* 8:669–674
- Steele MW, Chorazy AL (1974) Renpenning's syndrome. *Lancet* 1:752–753
- Stevenson RE, Goodman HO, Schwartz, CE, Simensen RJ, McLean WT Jr, Herndon CN (1990) Allan-Herndon syndrome. I. Clinical studies. *Am J Hum Genet* 47:446–453
- Sukpanichnant S, Vnencak-Jones CL, McCurley TL (1993) Detection of clonal immunoglobulin heavy chain gene rearrangements by polymerase chain reaction in scrapings from archival hematoxylin and eosin-stained histologic sections: implications for molecular genetic studies of focal pathologic lesions. *Diagn Mol Pathol* 2:168–176
- Sutherland GR, Gedeon AK, Haan EA, Woodroffe P, Mulley JC (1988) Linkage studies with the gene for an X-linked syndrome of mental retardation, microcephaly and spastic diplegia (MRX2). *Am J Med Genet* 30:493–508
- Turner G, Engisch B, Lindsay DG, Turner B (1972) X-linked mental retardation without physical abnormality (Renpenning's syndrome) in sibs in an institution. *J Med Genet* 9: 324–330
- Turner G, Turner B, Collins E (1970) Renpenning's syndrome—X-linked mental retardation. *Lancet* 2:365–366
- (1971) X-linked mental retardation without physical abnormality: Renpenning's syndrome. *Dev Med Child Neurol* 13:71–78
- van der Maarel S, Scholten I, Olde Weghuis D, Huber I, Röhme D, Gilgenkrantz S, Kere J, et al (1996) Cloning of candidate genes for X-linked mental retardation by use of chromosomal aberrations. *Am J Med Genet* 64:19
- Wilson M, Mulley J, Gedeon A, Robinson H, Turner G (1991) New X-linked syndrome of mental retardation, gynecomastia, and obesity is linked to DXS255. *Am J Med Genet* 40:406–413